

**SURVEY FOR:**  
4 SEASONS CONST., LLC  
2700 FALCON ST., #75  
WHITE CITY, OR 97503

**DATE:**  
DECEMBER 1, 2020

**SURVEY BY:**  
L.J. FRIAR & ASSOCIATES, P.C.  
CONSULTING LAND SURVEYORS  
P.O. BOX 1947  
PHOENIX, OR 97535  
PHONE: (541) 772-2782  
LJFRIAR@ASSOCIATES360CHARTER.NET  
WWW.FRIARANDASSOCIATES.COM

**439-20-00028-SUB DEEDS**

ADJUSTED TRACT 1 (PLA #1) = DOC. # 2020-047863 , ORJCO

ADJUSTED TRACT 2 (PLA #1) = DOC. # 2020-047868 , ORJCO

**439-20-00033-SUB DEEDS**

ADJUSTED TRACT 2 (PLA #2) = DOC. # 2020-047869 , ORJCO

ADJUSTED TRACT 3 (PLA #2) = DOC. # 2020-047870 , ORJCO

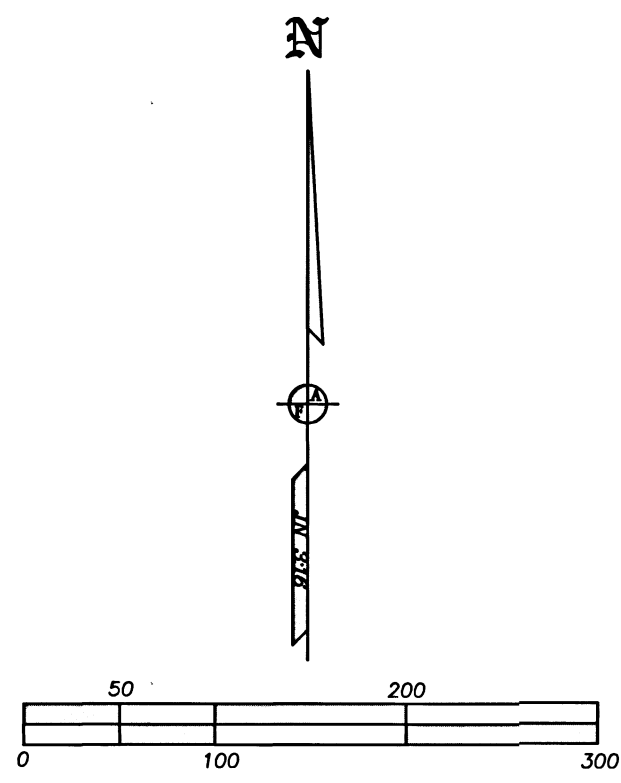

**\*\*\* JACKSON COUNTY DEVELOPMENT SERVICES \*\*\***  
FILE NO. 439-20-00028-SUB & 439-20-00033-SUB

EXAMINED AND APPROVED THIS 22nd DAY OF December, 2020.

BY: Kenneth Skyles  
KENNETH SKYLES, Planner II

**MAP OF SURVEY**  
**PROPERTY LINE ADJUSTMENT**  
In the N.E. 1/4 of Sec. 25, T.36S., R.3W., W.M.  
Jackson County, Oregon  
(JCDS File 439-20-00028-SUB & 439-20-00033-SUB)

**LEGEND:**

- ⊙ = FD. COUNTY SURVEYOR'S BRASS CAPPED MONUMENT PER <YEAR> RE-ESTAB'S.
- = FD. 2" IRON PIPE PER HHS.
- = FD. 1.5" X 3" CHANNEL IRON. SEE FS3713.
- ⊗ = FD. 5/8" IRON PIN & PLASTIC CAP MKD. KAISER RLS803 PER FS17142.
- ⊙ = FD. 5/8" IRON PIN & PLASTIC CAP MKD. TEMPLIN LS2359 PER FS19258.
- ⊙ = FD. 5/8" IRON PIN PER FS3713.
- ⊙ = FD. 5/8" IRON PIN & 2" BRASS CAP MKD. MILLS LS1915 PER FS19515.
- = SET 5/8" X 24" IRON PIN & PLASTIC CAP MKD. L.J. FRIAR & ASSOC.

- JCDR = JACKSON COUNTY DEED RECORDS.
- ORJCO = OFFICIAL RECORDS OF JACKSON COUNTY, OREGON.
- FS = FILED SURVEY #
- HHS = HAPPY HOLLOW SUBDIVISION.
- { } = RECORD DATA PER FS19515.
- OPL1 = ORIGINAL PROPERTY LINE UNDER 439-20-00028-SUB.
- APL1 = ADJUSTED PROPERTY LINE UNDER 439-20-00028-SUB.
- PLA #1 = PLANNING FILE 439-20-00028-SUB.
- OPL2 = ORIGINAL PROPERTY LINE UNDER 439-20-00033-SUB.
- APL2 = ADJUSTED PROPERTY LINE UNDER 439-20-00033-SUB.
- PLA #2 = PLANNING FILE 439-20-00033-SUB.

**SURVEY NARRATIVE TO COMPLY WITH O.R.S. 205.250**

**PURPOSE:** To survey and monument three tracts resulting from two property line adjustments of a portion of Vol. 209, Pg. 372 and those tracts set forth in Vol. 400, Pg. 282, Vol. 402, Pg. 159 & Vol. 449, Pg. 414, JCDR. See JCDS File No. 439-20-00028-SUB and 439-20-00033-SUB.

**PROCEDURE:** Using Trimble R10 G.P.S receivers & Trimble S6 Robotic Total Station, made ties to the existing monuments as shown hereon to control this survey. Used data per FS19515 to position the centerline of Interstate No. 5. I then offset this line 200' to position the R/W of said Interstate No. per Vol. 449, Pg. 414, JCDR. Used the found monuments to position the remaining boundaries as shown. I then computed the position of the adjusted tracts per the approved Site Plans and set monuments for the final adjusted tracts as shown hereon. Prepared legal descriptions of the adjusted tracts for both adjustments to be used on the adjustment deeds.

**BASIS OF BEARINGS:**  
SURVEY NO. 17142 AS SHOWN HEREON.  
UNIT OF MEASUREMENT = FEET      SCALE: 1" = 100'

REGISTERED PROFESSIONAL LAND SURVEYOR  
James E. Higgs  
OREGON  
JULY 17, 1988  
JAMES E. HIGGS  
2234  
RENEWAL DATE: 6-30-21

FILED  
Date: 12/23/2020 By: DR  
This Survey Consists Of:  
1 sheet(s) Map  
0 page(s) Narrative  
JACKSON COUNTY SURVEYOR