

MAP OF SURVEY
 Lot 6, Block A, JESSELS SUBDIVISION &
 located in the S.E. 1/4 of Section 9,
 T.39S, R.1E, W.M. City of Ashland
 Jackson County, Oregon

SURVEY FOR:
 DEBORAH ZUCKER
 356 IDAHO ST.
 ASHLAND, OR 97520

SURVEY BY:
 L.J. FRIAR & ASSOCIATES, P.C.
 CONSULTING LAND SURVEYORS
 PO BOX 1947
 PHOENIX, OR 97535
 PHONE: (541) 772-2782
 LJFRIAR@ASSOCIATES@CHARTER.NET

DATE:
 OCTOBER 28, 2019

LEGEND:

- = FOUND 3" BRASS DISK MKD. 'CITY OF ASHLAND SURVEY MONUMENT NO.' IN MONUMENT CASE, PER FSS298, UNLESS NOTED.
- = FD. 5/8" IRON PIN & PLASTIC CAP MKD. SWAIN RLS759 PER FS5203.
- = SET 5/8" X 24" IRON PIN & PLASTIC CAP MKD. L.J. FRIAR & ASSOC.
- △ = SET TEMPORARY 60D NAIL ON PROPERTY LINE FOR FENCING PURPOSES.

ORJCO = OFFICIAL RECORDS OF JACKSON COUNTY, OREGON.

- WC = WITNESS CORNER.
- () = RECORD DATA PER JS.
- JS = JESSELS SUBDIVISION
- FS = FILED SURVEY #
- X- = FENCE LINE.
- { } = RECORD DATA PER FS5298.
- { } = DISTANCE WEST OR SOUTH FROM N.E. CORNER TO 60D NAIL.

BASIS OF BEARINGS:

SURVEY NO. 5203 AS SHOWN HEREON.

UNIT OF MEASUREMENT = FEET SCALE: 1" = 20'

SURVEY NARRATIVE TO COMPLY WITH O.R.S. 209.250

PURPOSE: TO SURVEY AND MONUMENT THE CORNERS OF LOT 6, BLOCK A OF JESSELS SUBDIVISION, BEING DOC. 2018-028130, ORJCO, AND TO MARK THE NORTH AND EAST LINES FOR FENCING PURPOSES.

PROCEDURE: USING TRIMBLE R8 G.P.S. RECEIVERS AND TRIMBLE SB ROBOTIC TOTAL STATION, MADE TIES TO MONUMENTS OF RECORD AS SHOWN HEREON TO CONTROL THE R/W AND THE SUBJECT TRACT. HELD THE NORTH LINE OF JESSEL'S SUBDIVISION PARALLEL TO HOLLY STREET AS WAS DONE BY FS5203. COMPUTED THE CORNER POSITIONS OF BLOCK A AS SHOWN AND THEN USED PROPORTIONATE METHOD TO COMPUTE THE POSITIONS OF THE S.W. & S.E. LOT CORNERS. I THEN SET MONUMENTS AT THE LOCATIONS AS SHOWN HEREON. SET TEMPORARY CONSTRUCTION STAKES AS SHOWN FOR FENCE BUILDING PURPOSES.

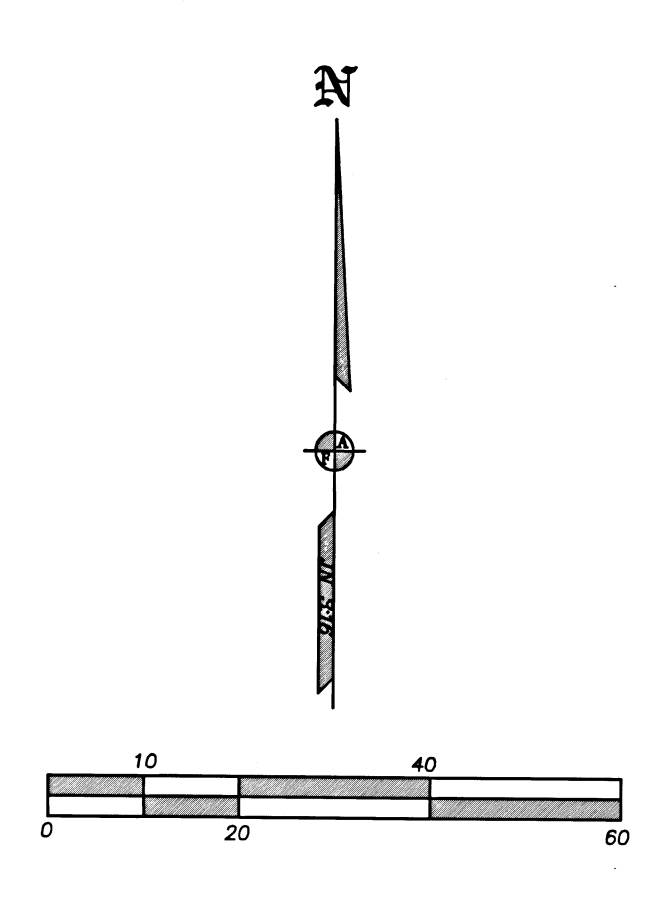
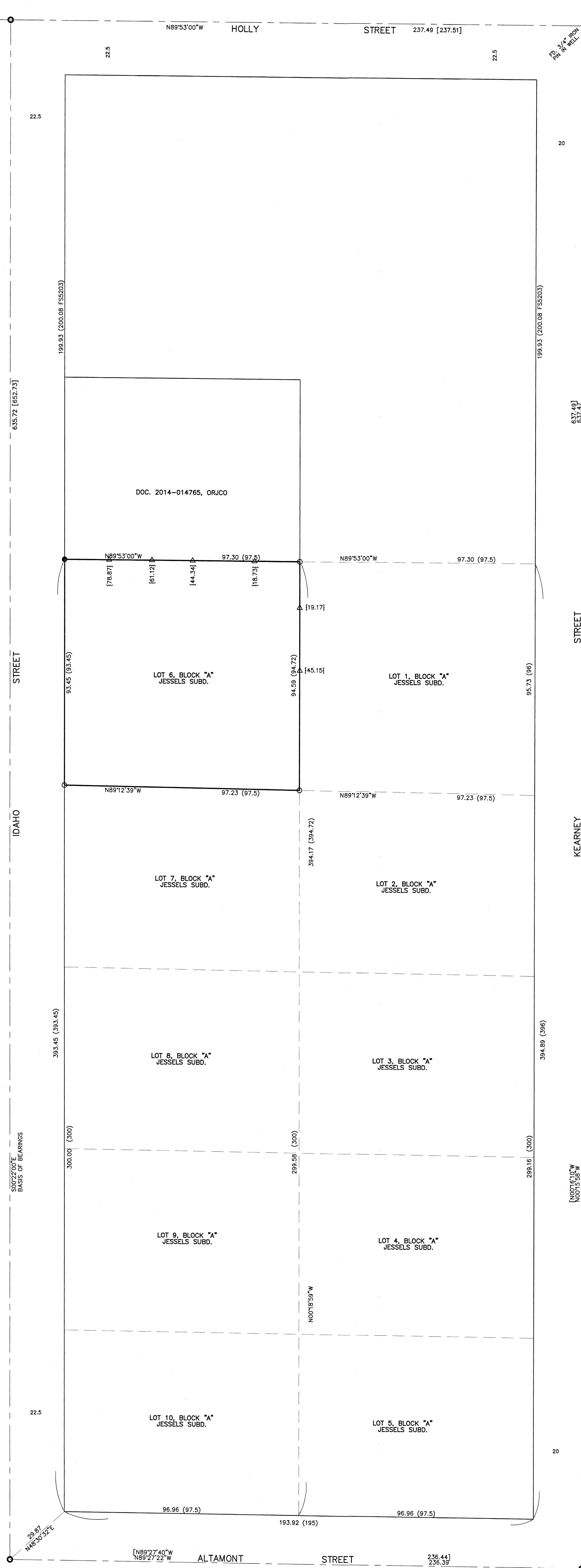

REGISTERED PROFESSIONAL LAND SURVEYOR
 L.J. Friar
 OREGON
 JULY 17, 1988
 JAMES E. HIBBS
 2234
 RENEWAL DATE: 6-30-21

FILED
 Date 10/28/19 By [Signature]
 This Survey Consists Of:
 1 sheet(s) Map
 0 page(s) Narrative
 JACKSON COUNTY SURVEYOR