

- ⊗ = SET 4" MAG NAIL & 2.5" BRASS WASHER MKD. FRIAR & ASSOC. IN ASPHALT.
- ⊗ = SET 1" MAG NAIL & 1" BRASS TAG MKD. FRIAR & ASSOC. IN CONCRETE.

REGISTERED
PROFESSIONAL
LAND SURVEYOR

J. E. Hibbs

OREGON
JULY 17, 1986
JAMES E. HIBBS
2234

RENEWAL DATE: 6-30-19

TITLE:
POST MONUMENT EXHIBIT

ASSESSOR'S MAP #:
WILLIAM WAY SUBDIVISION, PHASES 1 & 2

FOR: **WILLIAM WAY DEVELOPMENT LLC**
PO BOX 1313
TALENT, OR 97540

DATE:
8 MAY 2018

SCALE:
1 inch : 40 feet

DRAWN BY JEH
CHK BY:

ORIGIN:

ROTATION: 57°
JOB#: 16236FM

Sheet 1 of 2

 **L.J. FRIAR & ASSOCIATES P.C.**
CONSULTING LAND SURVEYORS
P.O. Box 1947, Phoenix, OR 97535
Phone: (541) 772-2782
Email: ljfriar@charter.net

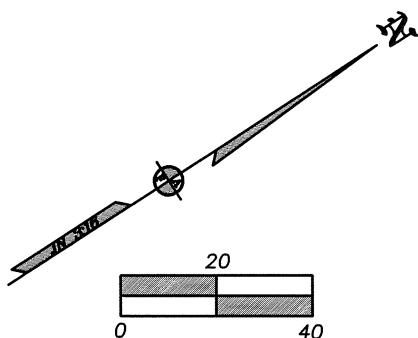
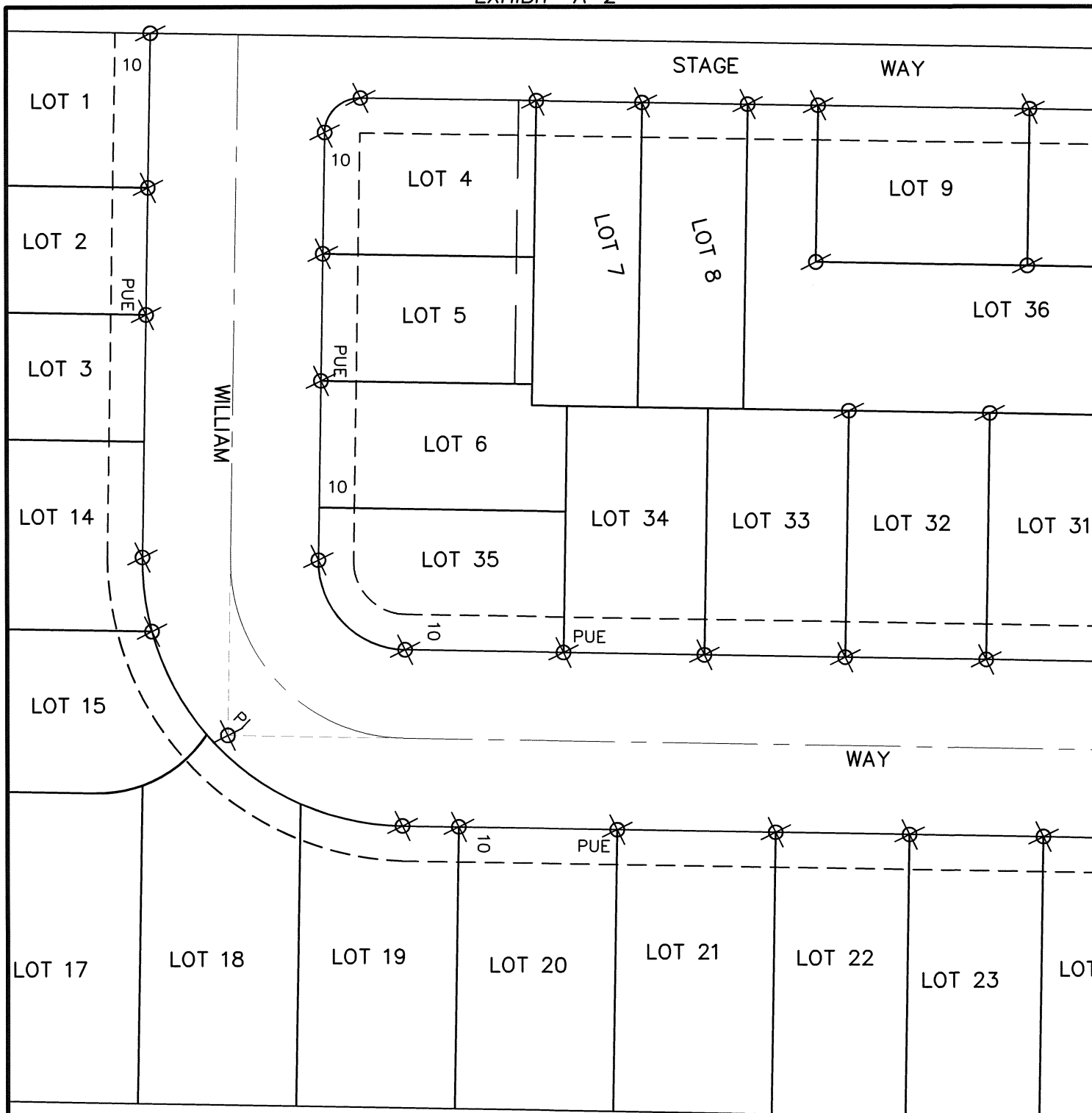

- ⊗ = SET 4" MAG NAIL & 2.5" BRASS WASHER MKD. FRIAR & ASSOC. IN ASPHALT.
- ⊗ = SET 1" MAG NAIL & 1" BRASS TAG MKD. FRIAR & ASSOC. IN CONCRETE.

REGISTERED
PROFESSIONAL
LAND SURVEYOR

James E. Hibbs

OREGON
JULY 17, 1986
JAMES E. HIBBS
2234

RENEWAL DATE: 6-30-19

© L.J. FRIAR & ASSOCIATES, P.C. 2018

TITLE:
POST MONUMENT EXHIBIT

ASSESSOR'S MAP #:
WILLIAM WAY SUBDIVISION, PHASES 1 & 2

FOR: WILLIAM WAY DEVELOPMENT LLC
PO BOX 1313
TALENT, OR 97540



L.J. FRIAR & ASSOCIATES P.C.
CONSULTING LAND SURVEYORS
P.O. Box 1947, Phoenix, OR 97535
Phone: (541) 772-2782
Email: ljfriar@charter.net

DATE:
8 MAY 2018

SCALE:
1 inch : 40 feet

DRAWN BY JEH
CHK BY:

ORIGIN:

ROTATION: 57°
JOB#: 16236FM

Sheet 2 of 2