

TL 500

DOC. NO. 00-11628,
OFFICIAL RECORDS OF
JACKSON COUNTY, OREGON

(1332.27' PER S/N 8887)
S89°08'01"E 1332.15'

(SEE DETAIL)

125.14'

± 2' WITNESS
CORNER

S89°08'01"E
171.01'

± 2' WITNESS
CORNER

0.21'
S00°51'59"W

S00°51'59"W
30.00'

TL 1400

DOC. NO. 99-27311,
OFFICIAL RECORDS OF
JACKSON COUNTY, OREGON

2 1/2" BRASS
DISC STAMPED
T36S R4W
1/4S
819
CS
1982

684.68'

32.99'
(33.1' PER
S/N 8887)

662.57'
(RECORD PER S/N 8887)

N00°26'46"E 2650.13'
(N00°27'13"E 2650.14' PER S/N 8887)

E 1/16
CORNER

N00°16'51"E (RECORD PER S/N 8887)

660.64'
(RECORD PER S/N 8887)

N89°03'00"W 1330.26'
(1330.30' PER S/N 8887)

2 1/2" BRASS
DISC STAMPED
T36S R4W
819
17116
CS
1989

Map of Survey

For:
Gem Burke

Located in:
The Southeast 1/4 of Section 8,
Township 35 South, Range 4 West, W.M.,
Jackson County, Oregon

DETAIL

SCALE: 1" = 50'

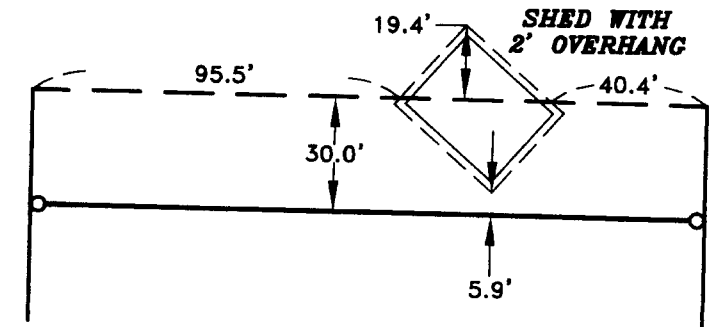

HOFFBUHR & ASSOCIATES, INC.
880 GOLF VIEW DR. STE. 201 MEDFORD, OREGON
(541) 779-4641

BY: DAVID M. MINNECI RPLS NO. 2349
SCALE: 1 INCH = 100' FEBRUARY 15, 2002
BASIS OF BEARING: SURVEY NUMBER 8887
(SOUTH LINE OF SECTION 8)

- = SET 5/8" x 24" IRON PIN WITH PLASTIC CAP STAMPED "D. MINNECI LS 2349".
- = FOUND 1/2" IRON PIN PER S/N 8887.
- = FOUND 5/8" IRON PIN PER S/N 5108 & 8887.
- ⊙ = FOUND BRASS CAP MONUMENT AS NOTED
- S/N = SURVEY NUMBER
- X - = EXISTING FENCELINE

REGISTERED
PROFESSIONAL
LAND SURVEYOR

David M. Minnecci
OREGON
JULY 26, 1988
DAVID M. MINNECI
2349

EXPIRES 12/31/10

**** RECEIVED ****

Date 6-18-09 By DM

This survey Consists of:

1 sheet(s) Map

1 page(s) Narrative

JACKSON COUNTY
SURVEYOR

**SURVEY NARRATIVE TO COMPLY WITH PARAGRAPH 209.250
OREGON REVISED STATUTES**

Survey for: Gem Burke
1810 Queens Branch Road
Rogue River, Oregon 97537

Location: The Southeast ¼ of Section 8, Township 35 South, Range 4 West,
Willamette Meridian, City of Medford, Jackson County, Oregon.

Purpose: To survey, monument and record a Map of Survey for a proposed
Property Line Adjustment. The deeds for the adjusted tax lots were
not signed and/or recorded, negating the proposed adjustment. The
resulting pins represent the proposed adjusted property line.

Gem Burke is no longer in ownership of the Southerly tax lot and it
is not known at this time if the shed overlapping the deeded line is
still in existence.

Procedure: I used found monuments from Survey No. 8887 and record bearing
and distance from the Southeast corner of Section 8 to establish
the common line of the affected tax lots. The proposed adjusted
line was established parallel and 30.00 feet Southerly of this line.
Witness corners were set on each side of the line as no attempt
was made to establish the Easterly and Westerly property lines of
tax lot 1400.

Basis of
Bearing: South line of Section 8 per Survey No. 8887.

Date: February 15, 2002 – June 17, 2009

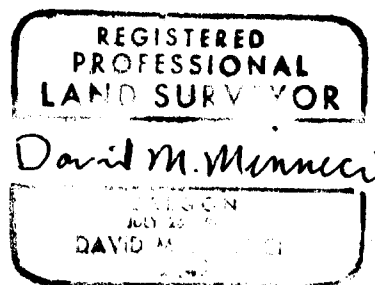

David M. Minneci
L.S. 2349 - Oregon
Expires 12/31/10
880 Golf View Dr., Suite 201
Medford, Oregon 97504

(Burkenar.doc)

