

**SURVEY FOR:**  
JOHN BRENDEN  
232 TIFFANY AVENUE  
CENTRAL POINT, OR 97502

**SURVEY BY:**  
L.J. FRIAR & ASSOCIATES, P.C.  
CONSULTING LAND SURVEYORS  
816 WEST EIGHTH STREET  
MEDFORD, OREGON 97501  
PHONE: (541) 772-2782  
EMAIL: ljfriar@charter.net

**DATE:**  
AUGUST 4, 2006

# MAP OF SURVEY

Located in the N.E. 1/4 of Sec. 28, T.37S., R.2W., W.M.  
Jackson County, Oregon

**LEGEND:**

- ⊙ = FD. COUNTY SURVEYOR'S BRASS CAPPED MONUMENT PER RE-ESTAB'S.
- = FD. 5/8" IRON PIN PER FS2938.
- ⦿ = FD. 5/8" IRON PIN W/ PLASTIC CAP MKD. R.BATH LS1069 PER FS9120.
- = SET 5/8" X 30" IRON PIN W/ PLASTIC CAP MKD. L.J. FRIAR & ASSOC.

- JCDR = JACKSON COUNTY DEED RECORDS.
- ORJCO = OFFICIAL RECORDS OF JACKSON COUNTY, OREGON.
- WC = WITNESS CORNER.
- ( ) = RECORD DATA AS SHOWN.
- DR = DEED RECORD DATA.
- FS = FILED SURVEY #.
- X- = FENCE LINE.

**BASIS OF BEARINGS:**

WEST LINE DLC #67 PER FS9120 AS SHOWN.  
UNIT OF MEASUREMENT = FEET      SCALE: 1" = 100'

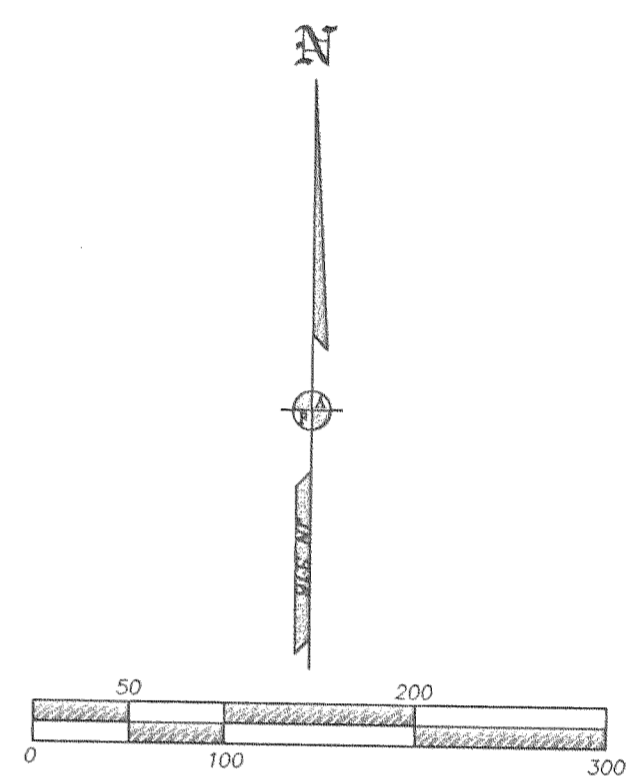

**SURVEY NARRATIVE TO COMPLY WITH O.R.S. 209.250**

**PURPOSE:** TO SURVEY AND MONUMENT THE CORNERS OF THAT TRACT DESCRIBED IN DOC. 2006-031401, ORJCO.

**PROCEDURE:** MADE TIES TO MONUMENTS OF RECORD AS SHOWN HEREON. COMPUTED THE POSITION OF THE SE COR & EAST LINE OF DLC #67 USING MAP RECORD DATA PER FS7353. THE NORTH LINE OF THE SUBJECT TRACT WAS HELD AS SHOWN ON FS7353. THE EAST LINE (BEING THE NORTH-SOUTH CENTERLINE OF VOL. 321, PG. 478, JCDR) WAS COMPUTED AS A SPLIT OF THE BEARINGS BETWEEN THE EAST & WEST LINES OF SAID TRACT RUNNING FROM THE MIDPOINT ON THE NORTH LINE OF SAID TRACT. THE SOUTH LINE WAS CONTROLLED BY VOL. 321, PG. 478, JCDR AND DOC. #02-37390, ORJCO. SET MONUMENTS AS SHOWN HEREON.

REGISTERED PROFESSIONAL LAND SURVEYOR  
*James E. Hibbs*  
OREGON  
JULY 17, 1986  
JAMES E. HIBBS  
2234  
RENEWAL DATE 6-30-07

\*\* RECEIVED \*\*  
DATE 9-29-06 BY RB  
This survey consists of:  
1 sheet(s) Map  
0 page(s) Narrative  
JACKSON COUNTY SURVEYOR